

QINGQI

MODEL.

H1E41QMB 型发动机

零件目录

PARTS CATALOGUE

济南轻骑摩托车股份有限公司

JINAN QINGQI MOTORCYCLE CO., LTD

前 言

本目录例图仅供查阅零件图号，不可作维修手册。如果您的轻骑牌摩托车需要更换零件时，请务必使用本公司纯正部品，因为这些部件均已通过严格检查，能够保证质量与工作性能。

本手册中的所有资料、图片及规格均系采用出版时的最新产品。由于改进或其他变化，本手册的记述可能与实际情况稍有出入，济南轻骑摩托车股份有限公司将保留随时修改的权利。

在未得到济南轻骑摩托车股份有限公司的事先允许，不得复制、引用和翻译本手册的任何部分。

使用说明：备注栏带(*)符号的零件表示构成总成的散件部件，不单独提供。

济南轻骑摩托车股份有限公司

PREFACE

Note that figures on the illustration page are only for reference of spare parts number, couldn't be used as a repairing manual.

When you have to have your QINGQI motorcycle repaired, please use QINGQI genuine spare parts to insure good performance, because these parts have been inspected strictly.

All information is about the latest product. The manufacturer reserves the right to vary specifications if any improvement or change occurs.

Neither duplication nor quotation is allowed without prior written consent.

All parts marked with (*) are components of an assembly, these parts can not be supplied separately.

Jinan Qingqi Motorcycle Co., Ltd.

零部件目录

PARTS CATALOGUE

Ref. No.	Description	Page
图 E1 FIGE1 气缸	CYLINDER	1
图 E2 FIGE2 箱体	CRANKCASE	2
图 E3 FIGE3 左箱盖	LEFT CRANKCASE COVER.....	4
图 E4 FIGE4 曲柄连杆机构	CRANKSHAFT.....	5
图 E5 FIGE5 化油器	CARBURETOR.....	6
图 E6 FIGE6 机油泵	OIL PUMP.....	9
图 E7 FIGE7 冷却风扇	COOLING FAN.....	10
图 E8 FIGE8 驱动盘	DRIVING FACE	11
图 E9 FIGE9 后离合器和减速齿轮	TRANSMISSION AND GEAR.....	13
图 E10 FIGE10 起动轴	KICK STARTER	15
图 E11 FIGE11 起动电机	STARTING MOTOR.....	16
图 E12 FIGE12 磁电机	MAGNETO	17
图 E13 FIGE13 限速装置	TRIGGER	18

FIG.E1



图 E1

气缸

FIG.E1

CYLINDER

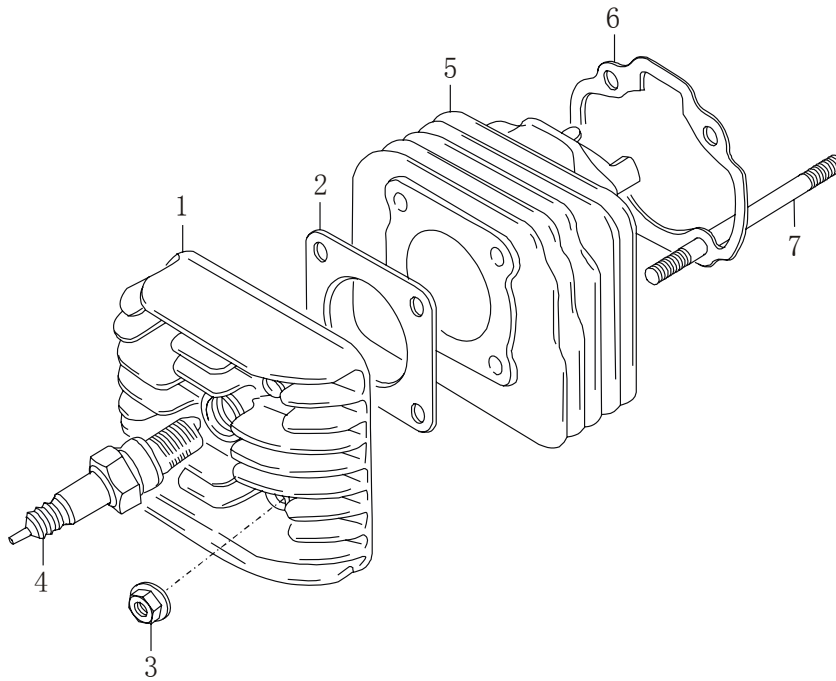
序号 Ref.No.	代号 Part No.	名称及规格 Description	数量 Q'ty	备注 Remarks
1	H1E41QMB.02-4	气缸盖 Cylinder head	1	
2	H1E41QMB.02-1	气缸盖垫片 Gasket, cylinder head	1	
3	GB6177.1-2000	螺母 M6 Nut M6	4	10级
4	H1E41QMB.02-6	火花塞 E7RTC Spark plug E7RTC	1	
5	H1E41QMB.02-5	气缸体 Cylinder	1	
6	H1E41QMB.02-2	气缸垫片 Gasket, cylinder	1	
7	H1E41QMB.02-3	双头螺栓 Stud	4	

FIG.E2



图 E2

箱体

FIG.E2

CRANKCASE

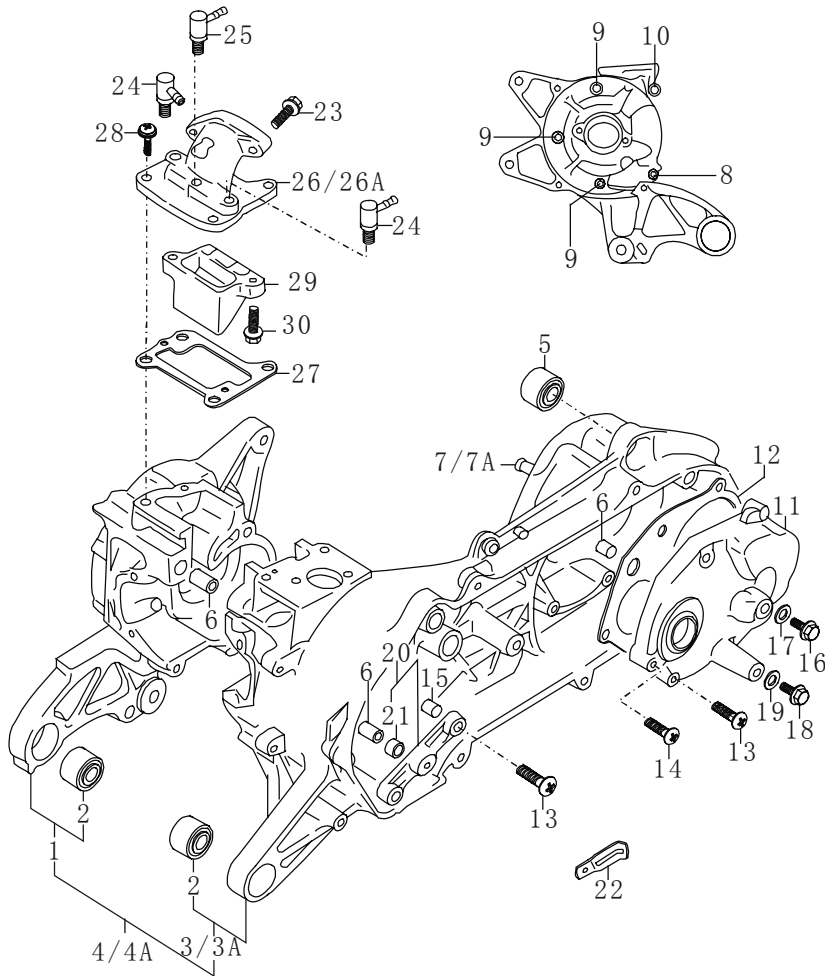
序号	代号	名称及规格	数量	备注
Ref.No.	Part No.	Description	Q'ty	Remarks
1	H1E41QMB01-02	右箱体 Crankcase, RH	1	
2	H1E41QMB01.1-00	衬套 Bush	2	
3	H1E41QMB.01-01	左箱体 Crank case, LH	1	
3A	H1E41QMB-A.01-01	左箱体 Crank case, LH	1	加长机
4		左右箱体组合 Crankcase assy	1	
4A		左右箱体组合 Crankcase assy	1	加长机
5	H1E41QMB01.2-00	衬套 Bush, rear shock absorber	1	
6	H1E41QMB01-05	定位销 Dowel pin	6	
7	H1E41 QMB.01-19	盘销 Pin, brake shoes	1	
7A	H1E52QMG01-19	盘销 Pin, brake shoes	1	加长机
8	GB8182000	螺钉 M6×80 Screw M6×80	1	
9	GB818-2000	螺钉 M6×85 Screw M6×85	3	
10	GB818-2000	螺钉 M6×45 Screw M6×45	1	
11	H1E41QMB01-07	齿轮箱盖 Cover, gear box	1	
12	H1E41QMB01-08	垫片 Gasket, gear box cover	1	
13	GB818-85	螺钉 M6×30 Screw M6×30	5	
14	GB818-85	螺钉 M6×25 Screw M6×25	1	
15	H1E41QMB01-13	定位销 Dowel pin	2	
16	GB5789-86-A	油面螺栓 M8×1.25×12 Bolt M8×1.25×12	1	
17	K157FMI.02-25	垫圈 Washer	1	借用

FIG.E2



图 E2

箱体

FIG.E2

CRANKCASE

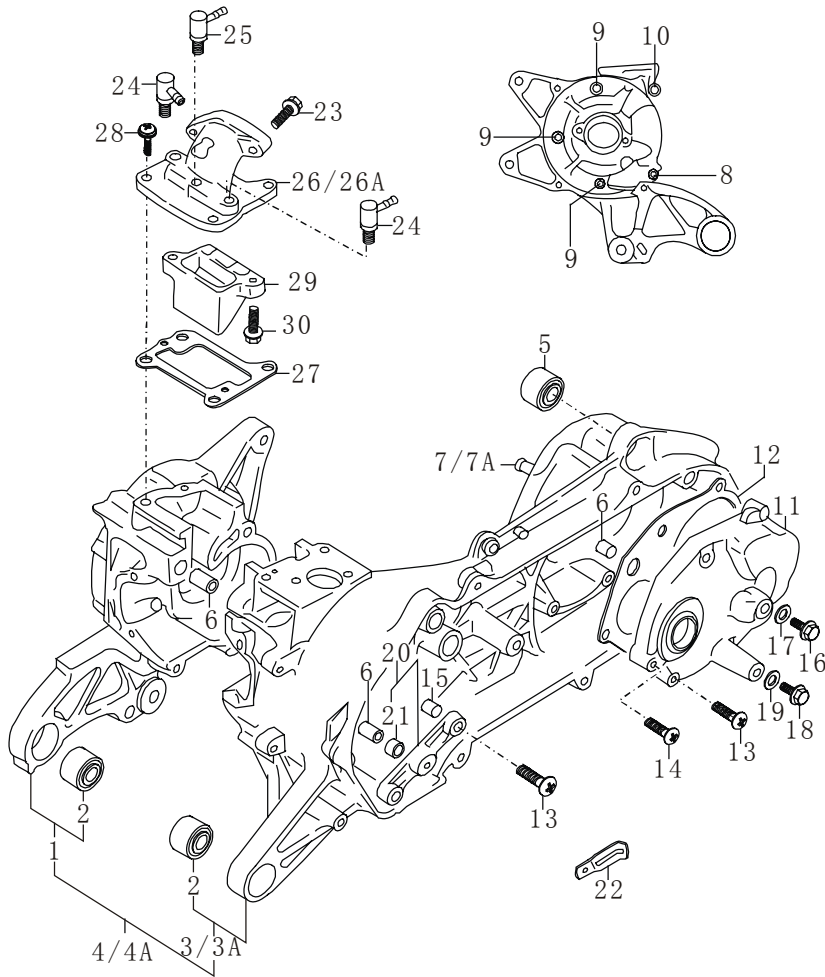
序号	代号	名称及规格	数量	备注
Ref.No.	Part No.	Description	Q'ty	Remarks
18	GB5789-86-A	放油螺栓 M6×12	1	
19	K157FMI.01.4-00	垫片	1	借用
20	H1E41QMB01-09	启动惰轮压盖	1	
21	H1E41QMB01-15	衬套	2	
22	H1E41QMB01-10	夹子	1	
23	GB9074.11	螺栓 M6×20	2	
24	H1E41QMB.14.04-00	管接头	2	
25	H1E41QMB.14.03-00	单向阀	2	
26	H1E41QMB14-4	进气管	1	
26A	H1E41QMB-A.14.4-00	进气管	1	QM50T-10V 专用
27	H1E41QMB14-3	簧片阀衬垫	1	
28	GB9074.7	螺钉 M6×20	4	
29		簧片阀组合	1	
30	H1E41QMB14.02-00	簧片紧固螺钉	2	

FIG.E3

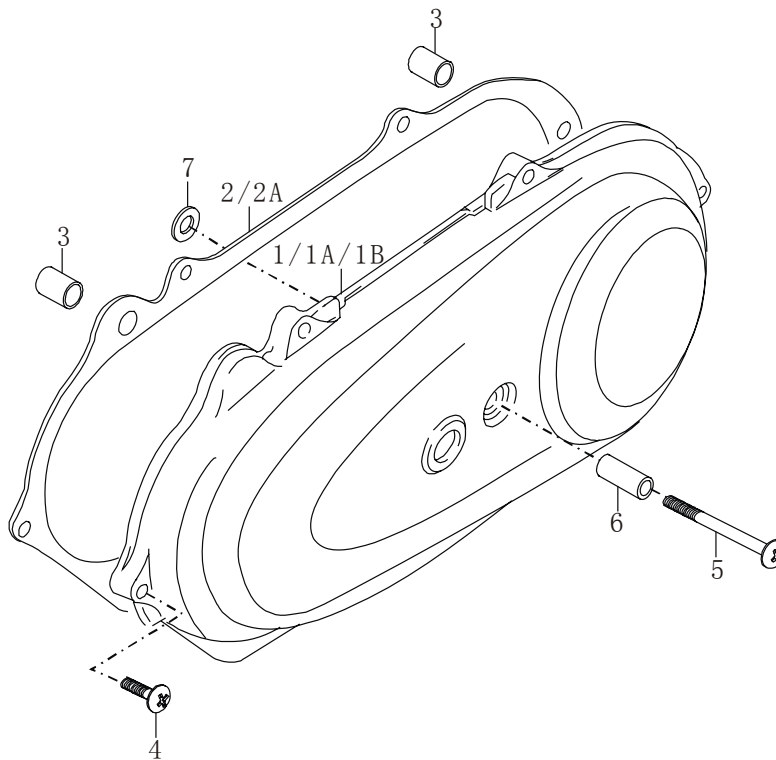

H1E41QMB

图 E3

左箱盖

FIG.E3

LEFT CRANKCASE COVER

序号	代号	名称及规格	数量	备注
Ref.No.	Part No.	Description	Q'ty	Remarks
1	H1E41QMB.01-03	离合器盖	1	
1A	H1E41QMB-A.01-03	离合器盖	1	加长机
1B	H1E41QMB-A.01-03A	离合器盖	1	后轮限速
2	H1E41QMB.01-04	垫片	1	
2A	H1E41QMB-A.01-04	垫片	1	加长机
3	H1E41QMB01-05	定位销	2	
4	GB818-2000	螺钉 M6×25H	6	
5	GB818-2000	螺钉 M6×65H	1	
6	H1E41QMB01-11	衬套	1	
7	H1E41QMB01-12	垫圈	1	

FIG.E4



图 E 4

曲柄连杆机构

FIG.E4

CRANKSHAFT

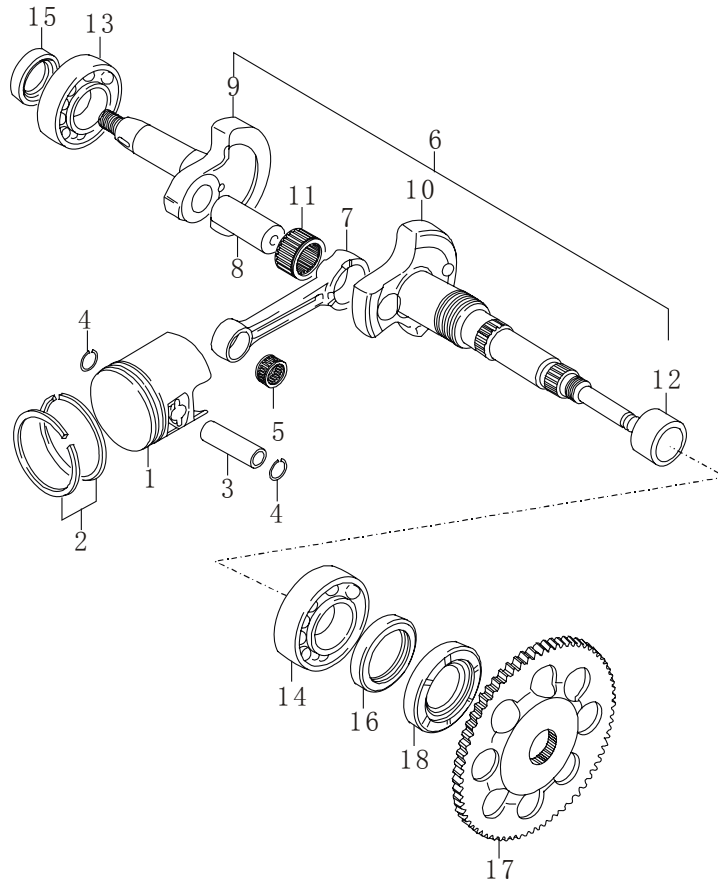
序号	代号	名称及规格	数量	备注
Ref.No.	Part No.	Description	Q'ty	Remarks
1	H1E41QMB.03-06	活塞 Piston	1	
2	H1E41QMB.03-07.08.09	活塞环 Ring set, piston	1	
3	H1E41QMB.03-05	活塞销 Pin, piston	1	
4	H1E41QMB.03-12	活塞销卡簧 Circlip	2	
5	H1E41QMB.03-10	活塞销轴承 Bearing	1	
6	H1E41QMB.03-00	曲柄连杆组合 Crankshaft assy	1	
7	H1E41QMB.03-04	连杆 Rod, connecting	1	*
8	H1E41QMB.03-03	曲柄销 Pin, crank	1	*
9	H1E41QMB.03-02	右曲柄 Crank, RH	1	*
10	H1E41QMB.03-01	左曲柄 Crank, LH	1	*
11	H1E41QMB.03-11	曲柄销轴承 Bearing	1	*
12	H1E41QMB.03-18	曲柄轴套 Spacer, crankshaft	1	*
13	H1E41QMB.03-14	右曲柄轴承 Bearing, RH	1	
14	H1E41QMB.03-13	左曲柄轴承 Bearing, LH	1	
15	H1E41QMB.03-16	右曲柄油封 Oil seal, RH	1	
16	H1E41QMB.03-15	左曲柄油封 Oil seal, LH	1	
17	H1E41QMB.06D-01	电起动齿轮 Gear, starter	1	
18	H1E41QMB.03-17	机油泵驱动齿轮油封 Oil seal	1	

FIG.E5



图 E5

化油器

FIG.E5

CARBURETOR

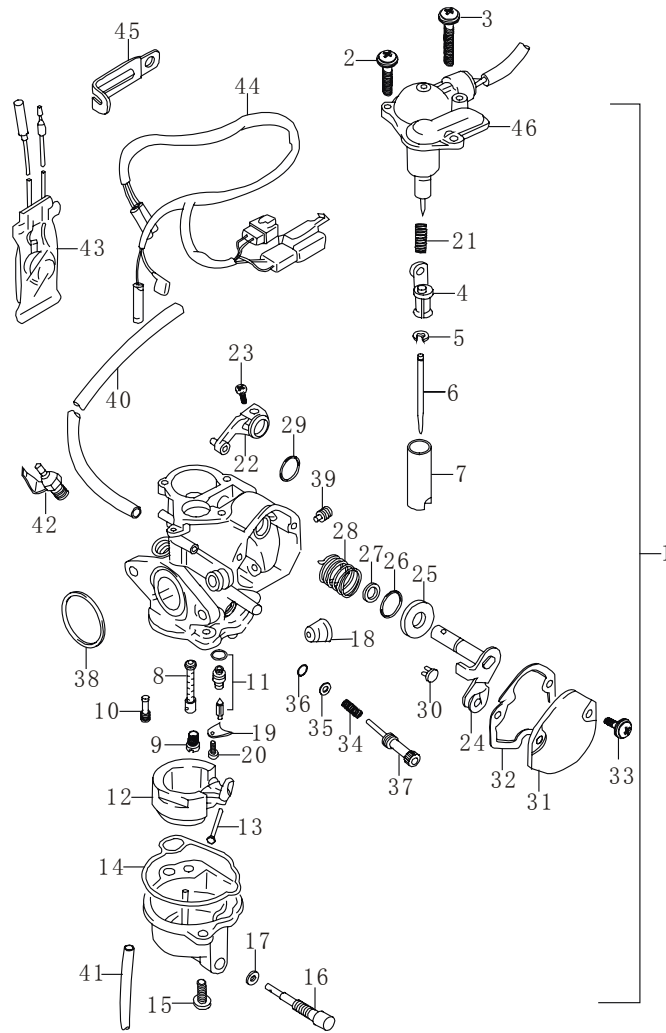
序号	代号	名称及规格	数量	备注
Ref.No.	Part No.	Description	Q'ty	Remarks
1	H1E41QMB.08-00	化油器总成 Carburetor assy	1	
2		螺钉 Screw	2	
3		螺钉 Screw	1	
4		接头 Joint	1	
5		调节针卡环 Clip, needle	1	
6		喷咀调节针 Needle, jet	1	
7		节气阀 Throttle, valve	1	
8		主喷管 Jet, needle	1	
9		主量孔 Jet, main	1	
10		怠速喷咀 Jet, pilot	1	
11		针阀组合 Valve assy, needle	1	
12		浮子 Float	1	
13		浮子销 Pin, float	1	
14		密封圈 Gasket	1	
15		螺钉 Screw	2	
16		放油螺钉 Screw drain	1	
17		O 型圈 O Ring	1	
18		化油器盖 Cap, carburetor	1	
19		挡片 Plate	1	
20		螺钉 Screw	1	

H1E41QMB

FIG.E5



图 E5

化油器

FIG.E5

CARBURETOR

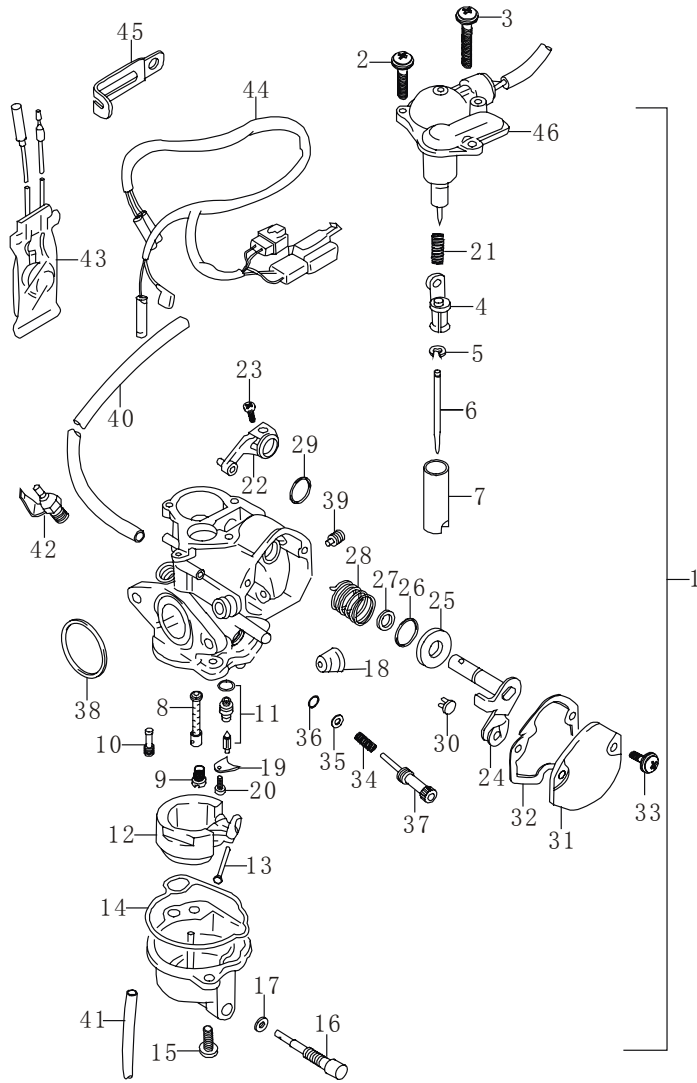
序号	代号	名称及规格	数量	备注
Ref.No.	Part No.	Description	Q'ty	Remarks
21		弹簧	1	
22		节气阀控制杆	1	
23		螺钉	1	
24		节气阀转轴组合	1	
25		挡圈	1	
26		环	1	
27		油封	1	
28		弹簧	1	
29		环	1	
30		拉线导座	1	
31		节气阀盖	1	
32		密封垫	1	
33		螺钉	1	
34		弹簧	1	
35		垫片	1	
36		O 型圈	1	
37		调节装置	1	
38		O 型圈	1	
39		空气量孔	1	
40		软管	1	

FIG.E5

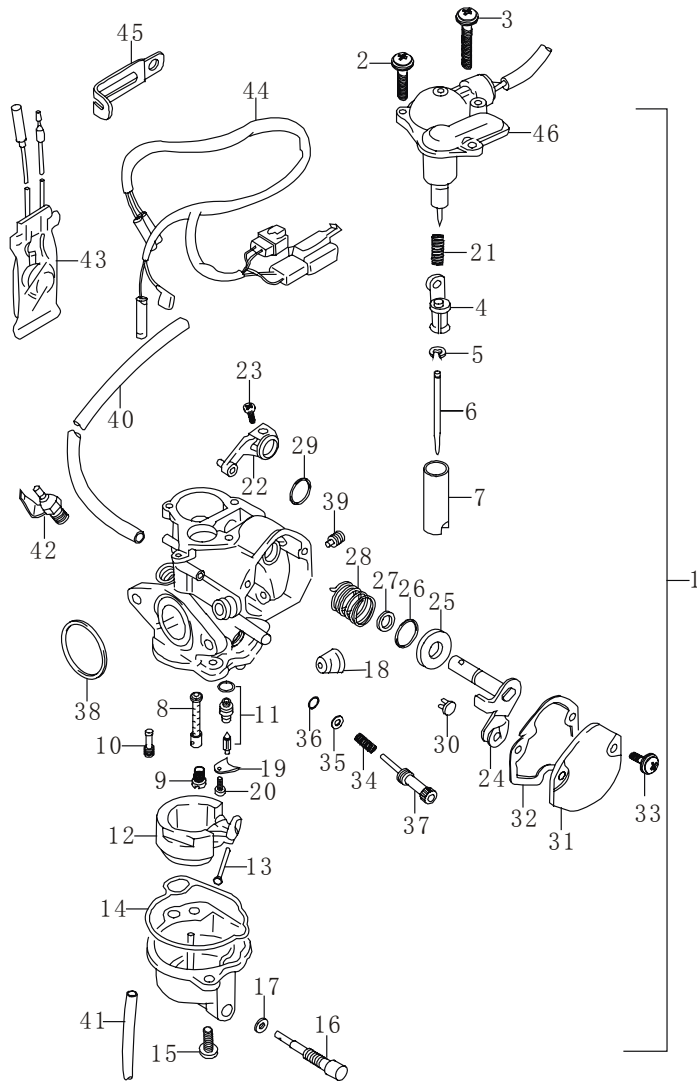

H1E41QMB

图 E5

化油器

FIG.E5

CARBURETOR

序号	代号	名称及规格	数量	备注
Ref.No.	Part No.	Description	Q'ty	Remarks
41		软管	1	
42		化油器加热器	1	
43		热敏开关	1	
44		加热器引线	1	
45		夹板	1	
46		起动加浓阀总成	1	

FIG.E6



图 E6

机油泵

FIG.E6

OIL PUMP

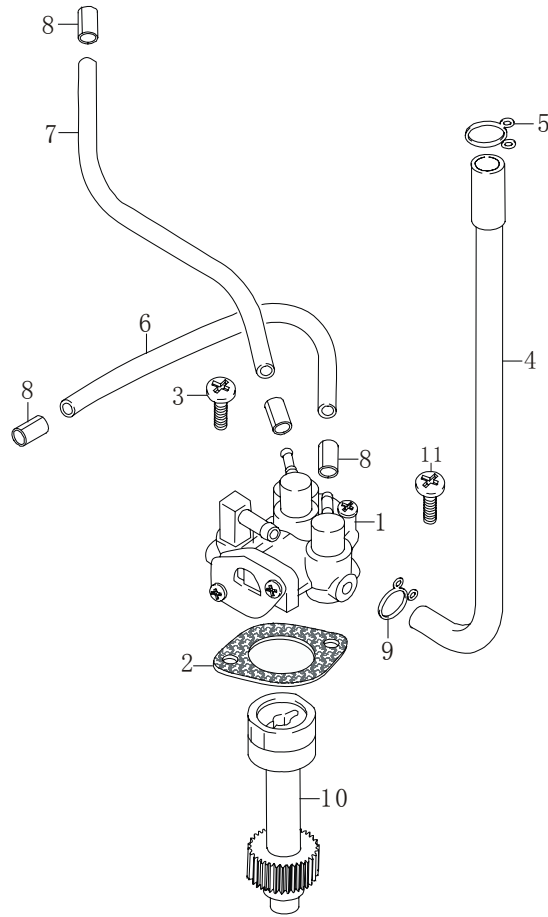
序号	代号	名称及规格	数量	备注
Ref.No.	Part No.	Description	Q'ty	Remarks
1	H1E41QMB.12.1-00	机油泵总成	1	
2	H1E41QMB.12-1	垫片	1	
3	GB9074.3-88	螺钉 M5×16	1	
4	H1E41QMB.12-10	油管	1	
5	H1E41QMB.12-11	油管夹子	1	
6	H1E41QMB.12-7	油管	1	
7	H1E41QMB12-5	油管	1	
8	H1E41QMB.12-8	卡箍	5	
9	H1E41QMB.12-11	油管卡子	1	
10	H1E41QMB.12-2	蜗轮	1	
11	GB9074.4-88	螺钉 M5×20	1	

FIG.E7

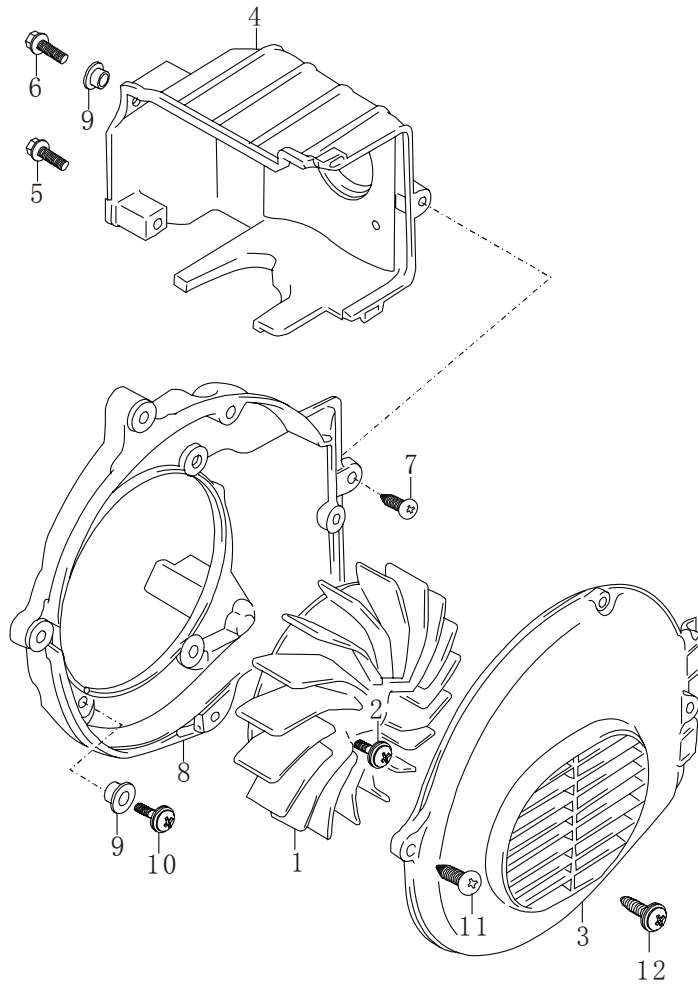

H1E41QMB

图 E 7

冷却风扇

FIG.E7

COOLING FAN

序号	代号	名称及规格	数量	备注
Ref.No.	Part No.	Description	Q'ty	Remarks
1	H1E41QMB.16.02-00	风扇	1	Fan, cooling
2	GB9074.1-88	螺钉组合件 M6×12	2	Screw M6×12
3	H1E41QMB.16-02	风扇罩	1	Cowling, fan
4	H1E41QMB.16.01-00	导流罩	1	Cowling, cylinder
5	GB9074.1-88	螺钉 M6×35	1	Screw M6×35
6	GB9074.4-88	螺钉 M6×25	1	Screw M6×25
7	GB9074.18-88	自攻螺钉 ST6.3×19	1	Screw ST6.3×19
8	H1E41QMB16-01	风扇壳	1	Case, fan
9	H1E41QMB.16-03	垫圈	5	Washer
10	GB823-88	螺钉 M6×16	4	Screw M6×16
11	GB845-85	自攻螺钉 ST6.3×25	2	Screw ST6.3×25
12	GB9074.18-88	自攻螺钉组合件 ST5.5×19	3	Screw ST5.5×19

FIG.E8

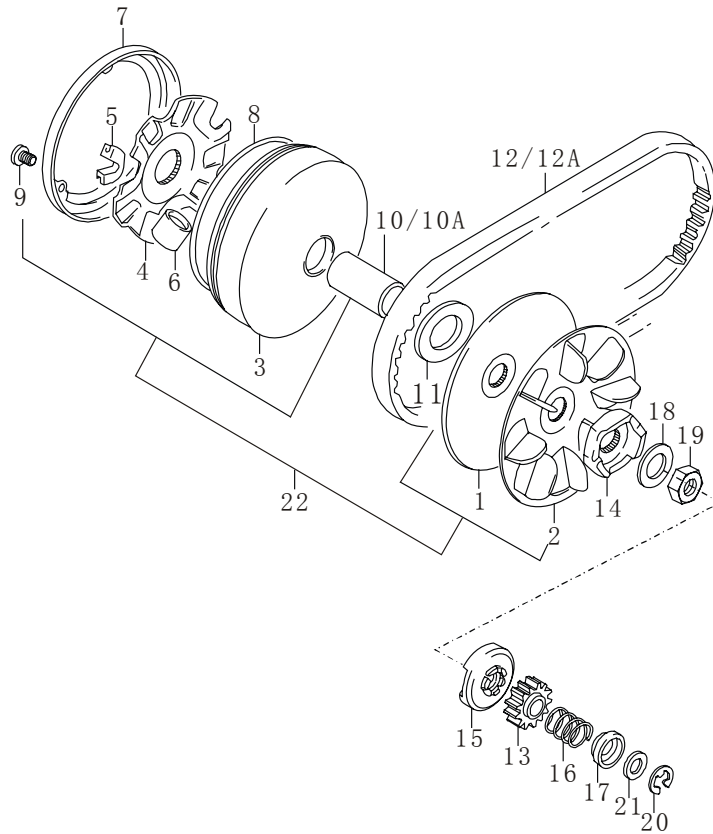

H1E41QMB

图 E 8

驱动盘

FIGE8

DRIVING FACE

序号	代号	名称及规格	数量	备注
Ref.No.	Part No.	Description	Q'ty	Remarks
1	H1E41QMB.04-21	固定驱动盘	1	*
2	H1E41QMB.04-20	风扇	1	*
3	H1E41QMB.04.7-00	移动驱动盘组合	1	*
4	H1E41QMB.04-03	导轨板	1	*
5	H1E41QMB.04-04	移动驱动盘缓冲器	3	*
6	H1E41QMB.04.6-00	滚柱	6	*
7	H1E41QMB.04-01	盖子	1	*
8	H1E41QMB.04-22	O 型圈	1	*
9	GB818-85	螺钉 M4×8	3	*
10	H1E41QMB.04-02	衬套	1	*
10A	H1E41QMB-A.04-01	衬套	1	限位加长机
11	H1E41QMB-A.04-02	限速挡圈	1	限位加长机
12	H1E41QMB.04-19	皮带	1	
12A	H1E41QMB-A.04-19	皮带	1	加长机
13	H1E41QMB.06.1-00	起动从动齿轮组合	1	
14	H1E41QMB.06-02	右棘轮	1	
15	H1E41QMB.06-03	左棘轮	1	
16	H1E41QMB.06-05	起动从动齿轮弹簧	1	
17	H1E41QMB.06-06	起动压套	1	
18	H1E41QMB.06-01	碟形垫圈	1	
19	H1E41QMB.06-04	起动螺母	1	

FIG.E8

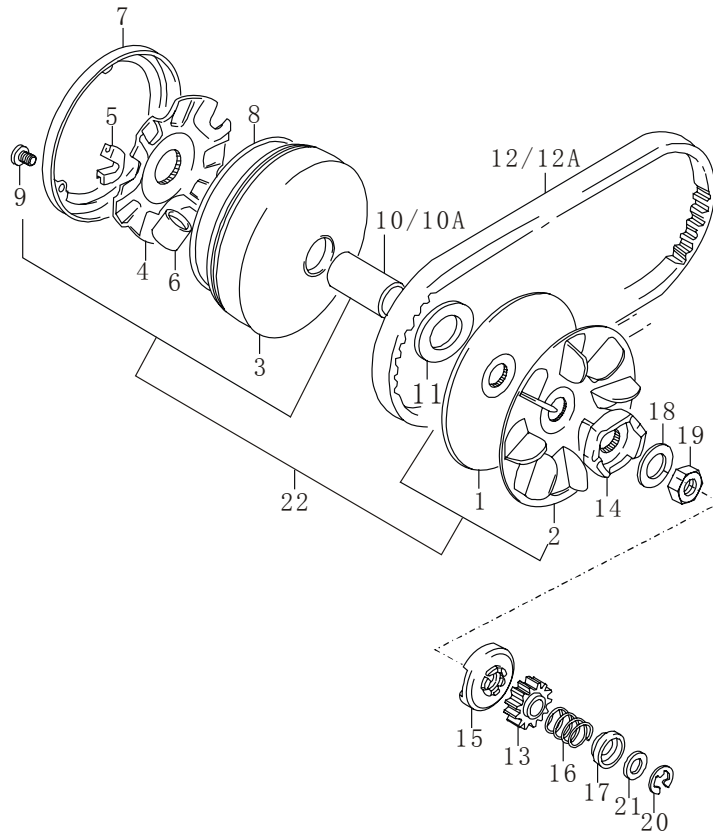

H1E41QMB

图 E 8

驱动盘

FIGE8

DRIVING FACE

序号 Ref.No.	代号 Part No.	名称及规格 Description	数量 Q'ty	备注 Remarks
20	H1E41QMB.06-08	E 型环 E Ring	1	
21	H1E41QMB.06-07	平垫圈 Washer	1	
22		前离合器总成 Clutch comp, drive	1	

FIG.E9



图 E9

后离合器和减速齿轮

FIG.E9

TRANSMISSION AND GEAR

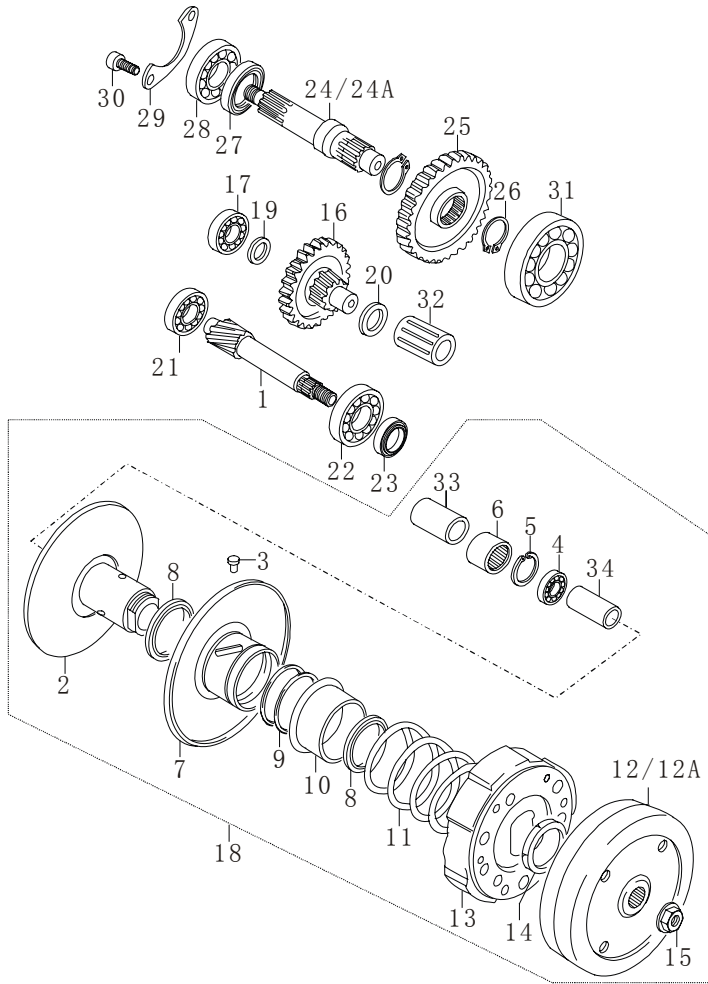
序号	代号	名称及规格	数量	备注
Ref.No.	Part No.	Description	Q'ty	Remarks
1	H1E41QMB.04-06	驱动轴	1	
2	H1E41QMB.04.5-00	固定从动盘组合	1	*
3	H1E41QMB.04-16	销	3	*
4	H1E41QMB.04-24	轴承	1	*
5	GB893.1-86	孔用弹性挡圈 28	2	*
6	H1E41QMB.04-28	轴承	1	*
7	H1E41QMB.04.2-00	从动滑盘组合	1	*
8	H1E41QMB.04.-18	油封	2	*
9	H1E41QMB.04-26	O 型圈	2	*
10	H1E41QMB.04-15	移动从动面座	1	*
11	H1E41QMB.04-17	压簧	1	*
12	H1E41QMB.04.4-00	离合器大毂组合	1	*
12A	H1E41QMB.04.4-00A	离合器大毂组合	1	*
13	H1E41QMB.04.3-00	传动盘组合	1	*
14	H1E41QMB.04-25	螺母	1	*
15	H1E41QMB.04-30	螺母	1	*
16	H1E41QMB.04.1-00	惰轮轴组件	1	
17	GB/T276-94	惰轮轴右轴承 6201	1	
18		后离合器	1	
19	H1E41QMB.04-07	推力垫圈 I	1	

FIG.E9

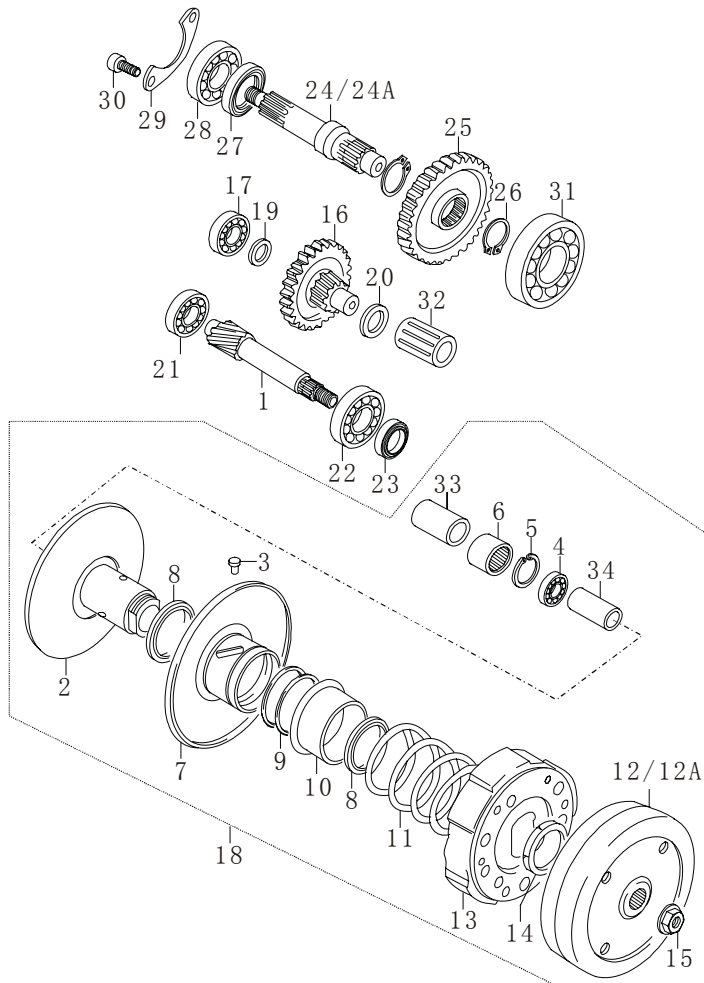

H1E41QMB

图 E9

后离合器和减速齿轮

FIGE9

TRANSMISSION AND GEAR

序号	代号	名称及规格	数量	备注
Ref.No.	Part No.	Description	Q'ty	Remarks
20	H1E41QMB.04-13	推力垫圈 II	1	
21	GB/T276-94	驱动轴右轴承 6201	1	
22	GB276-94	驱动轴左轴承 6303	1	
23	H1E41QMB.04-23	驱动轴油封	1	
24	H1E41QMB.04-09	后轴	1	
24A	H1E52QMG-A.04-01	后轴	1	QM50T-10E 专用
25	H1E41QMB.04-12	后轴从动齿轮	1	
26	H1E41QMB.04-11	轴用弹性挡圈 II	2	
27	H1E41QMB.04-10	后轴油封	1	
28	GB/T276-94	后轴右轴承 6204-2RS	1	
29	H1E41QMB.04-08	轴承压板	1	
30	GB819.2-1997	螺钉 M6×16	2	
31	GB/T276-94	后轴左轴承 6203	1	
32	H1E41QMB.04-14	惰轮轴左轴承	1	
33	H1E41QMB.04-27	衬套 I	1	*
34	H1E41QMB.04-29	衬套 II	1	*

FIG.E10

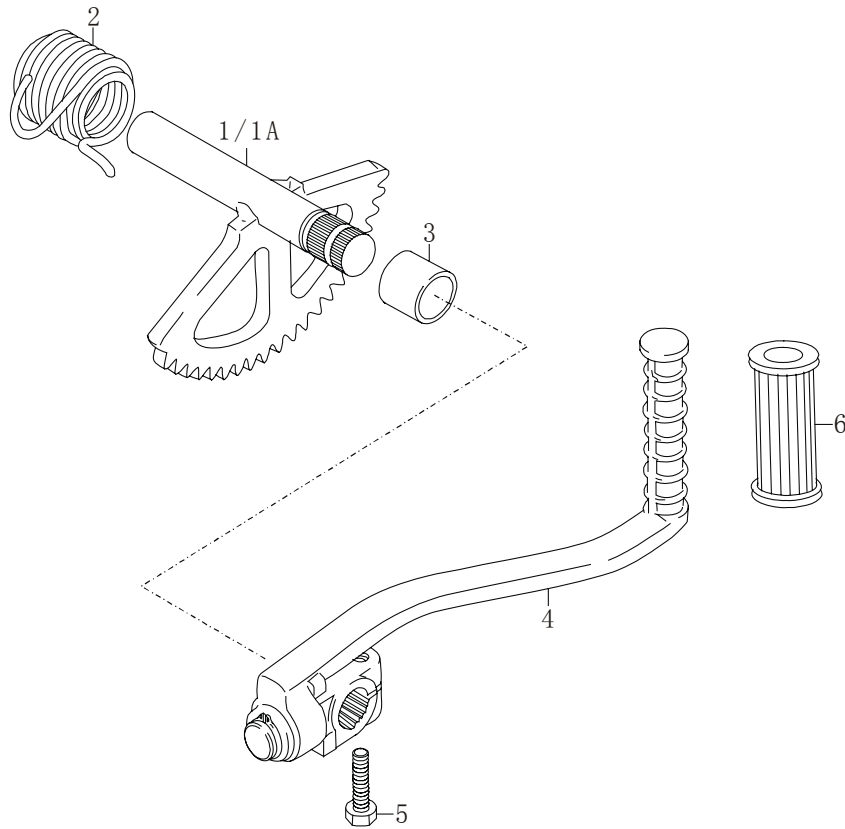

H1E41QMB

图 E10

起动轴

FIG.E10

KICK STARTER

序号	代号	名称及规格	数量	备注
Ref.No.	Part No.	Description	Q'ty	Remarks
1	H1E41QMB.06.3-00	反冲起动轴组合	1	
1A	H1E41QMB-A.06.3-00	反冲起动轴组合	2	加长机
2	H1E41QMB.06-11	起动轴回位弹簧	1	
3	H1E41QMB.06-9	反冲起动轴套	1	
4	H1E41QMB.06.2-00	起动杆组合	1	车
5	H1E41QMB.06-10	花键块螺栓	1	车
6		起动杆胶套	1	

FIG.E11

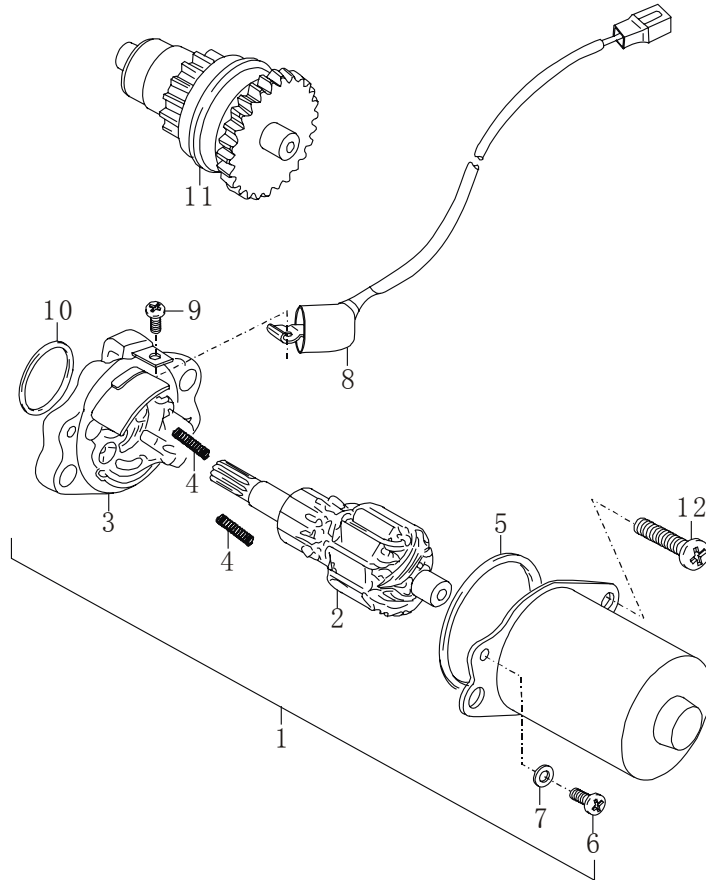

H1E41QMB

图 E11

起动电机

FIG.E11

STARTING MOTOR

序号	代号	名称及规格	数量	备注
Ref.No.	Part No.	Description	Q'ty	Remarks
1	H1E41QMB.06D.1.1-00	起动电机总成	1	
2		电枢组合	1	*
3		前端盖	1	*
4		电刷弹簧	2	*
5		密封圈	1	*
6		螺钉 M4×10	2	*
7		弹簧垫圈 4	2	*
8		线束	1	*
9		螺钉	1	*
10		密封圈	1	*
11	H1E41QMB.06D.1.2-00	离合器组合	1	
12	GB818-2000	螺钉 M6×25	2	

FIG.E12



图 E12

磁电机

FIG.E12

MAGNETO

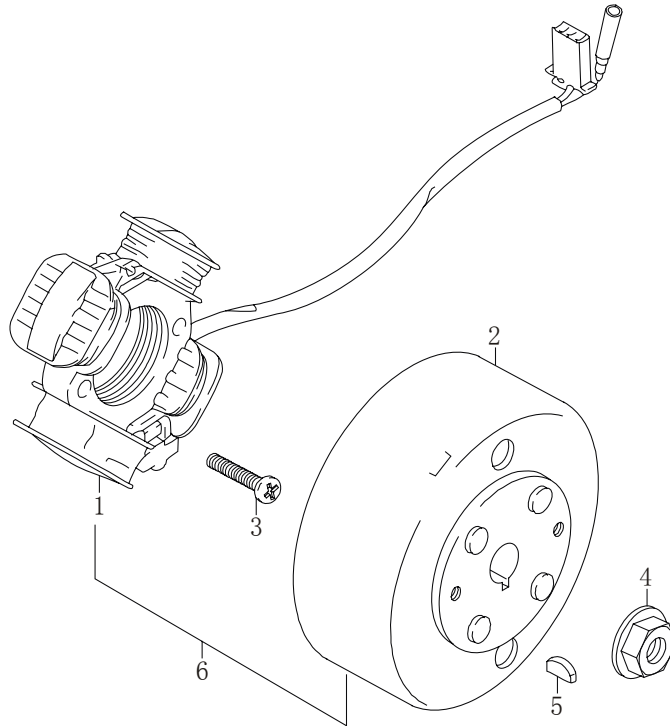
序号	代号	名称及规格	数量	备注
Ref.No.	Part No.	Description	Q'ty	Remarks
1	H1E41QMB07.1.2-00	定子组合	1	
2	H1E41QMB07.1.1-00	转子组合	1	
3	GB823-88	螺钉 M6×22	2	
4	GB6177.2-2000	螺母 M10×1.25	1	
5	GB1099.1-2003	半圆键 3×13	1	
6	H1E41QMB07.1-00	磁电机组合	1	

FIG.E13



图 E13

限速装置

FIG.E13

TRIGGER

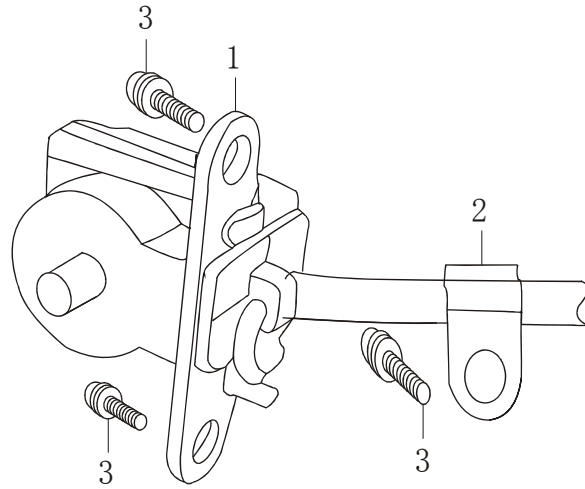
序号	代号	名称及规格	数量	备注
Ref.No.	Part No.	Description	Q'ty	Remarks
1	H1E41QMB-A.17-01	速度传感器 Trigger	1	
2	H1E41QMB-A.17-02	压线板 Plank	1	
3	GB9074.4-88	螺钉 M5×12 Screw M5×12	3	

本手册版权及最终解释权归济南轻骑摩托车股份有限公司所有。未得到济南轻骑摩托车股份有限公司的事先允许，不得复制、引用或翻印这本手册中的任何部分。

本手册的所有资料、解说、图片及规格均采用出版时的最新产品，由于改进或其它变化，本手册中的记述可能与实际情况稍有出入，济南轻骑摩托车股份有限公司将保留随时修改的权力。

产品规格参数更改恕不另行通知！

产品配置、配件供应因不同国家或区域不同而产生差异化，详情请咨询当地销售商！

Jinan Qingqi reserves the right to change, without prior written notice, of specifications, material and other items to each model.

Jinan Qingqi continually seeks advancement in products' improvement in different countries or areas, therefore while this manual contains the most current product information available at the time of printing, there may be minor discrepancies between your vehicle and this manual. If there is any question concerning this manual, please consult your local dealer.

All rights reserved. Any reprinting or unauthorized use without written permission of Jinan Qingqi Motorcycle Co.,Ltd. is expressly prohibited.

发行：济南轻骑摩托车股份有限公司

编辑：济南轻骑摩托车股份有限公司

版权所有 ● 请勿翻印

二零零七年第一版